

(19) World Intellectual Property Organization
International Bureau



(43) International Publication Date
28 June 2001 (28.06.2001)

PCT

(10) International Publication Number
WO 01/46960 A1

(51) International Patent Classification⁷: G21B 1/00

DE, DK, DM, DZ, EE, ES, FI, GB, GD, GE, GH, GM, HR, HU, ID, IL, IN, IS, JP, KE, KG, KP, KR, KZ, LC, LK, LR, LS, LT, LU, LV, MA, MD, MG, MK, MN, MW, MX, MZ, NO, NZ, PL, PT, RO, RU, SD, SE, SG, SI, SK, SL, TJ, TM, TR, TT, TZ, UA, UG, US, UZ, VN, YU, ZA, ZW.

(21) International Application Number: PCT/GR00/00041

(22) International Filing Date:
20 December 2000 (20.12.2000)

(25) Filing Language: English

(84) Designated States (regional): ARIPO patent (GH, GM, KE, LS, MW, MZ, SD, SL, SZ, TZ, UG, ZW), Eurasian patent (AM, AZ, BY, KG, KZ, MD, RU, TJ, TM), European patent (AT, BE, CH, CY, DE, DK, ES, FI, FR, GB, GR, IE, IT, LU, MC, NL, PT, SE, TR), OAPI patent (BF, BJ, CF, CG, CI, CM, GA, GN, GW, ML, MR, NE, SN, TD, TG).

(26) Publication Language: English

(30) Priority Data:
990100439 22 December 1999 (22.12.1999) GR

Published:
— With international search report.

(71) Applicant and
(72) Inventor: NASSIKAS, Athanassios [GR/GR]; 10, Ethnikis Antistasseos str., GR-413 35 Larissa (GR).

For two-letter codes and other abbreviations, refer to the "Guidance Notes on Codes and Abbreviations" appearing at the beginning of each regular issue of the PCT Gazette.

(81) Designated States (national): AE, AG, AL, AM, AT, AU, AZ, BA, BB, BG, BR, BY, BZ, CA, CH, CN, CR, CU, CZ,

(54) Title: SPACE-TIME ENERGY PUMP

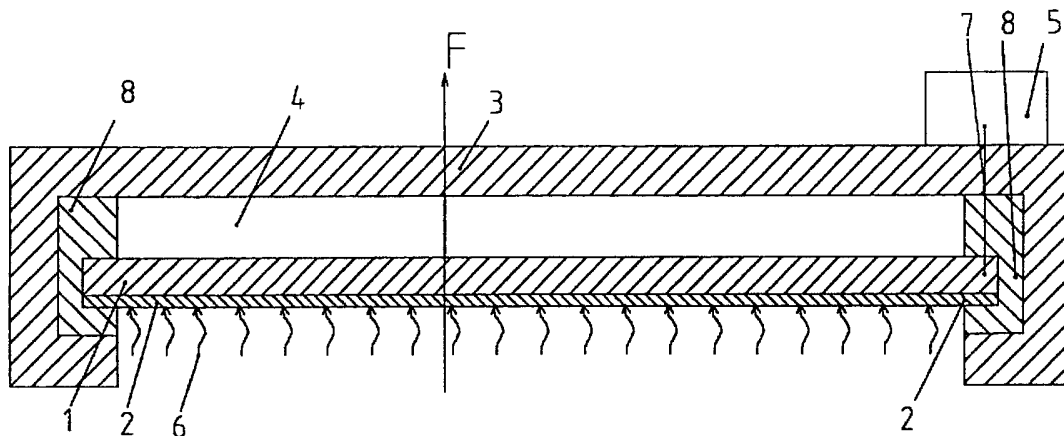

(57) Abstract: The present invention aims at the creation of hydrogenated carrier on the one side of a metallic system, the electric isolation of the said system and the exertion of negative potential on it. The result of this process is the absorption of ether gravitational space. The absorption of ether gravitational space is achieved by the oscillations of the hydrogen atom electrons of the hydrogenated carrier, by means of unstable states, lower than the 1st fundamental level. During the approach between electron and proton, it takes place an absorption of ether gravitational space in the hydrogenated carrier which, by means of the conversion process through photons, is finally converted either into heat or directly into mechanical work, developing a force resulting from the creation of probability density difference at the system's ends. This difference is created due to the reduction of the ether matter presence probability that creates the gravity at the area of the hydrogenated carrier. The embodiment of the invention is achieved either by means of a heater utilizing the rejected heat or by the production of mechanical work due to developed force, or by production of electric energy by means of a generator through conversion of mechanical work into rotary motion.



WO 01/46960 A1

SPACE-TIME ENERGY PUMP

a. Preface

The present invention description is based on the existing theoretical background and includes the description of a space-time energy pumping process based on the above mentioned background and the description of particular applications of the above mentioned process. Especially, the proposed method and the proposed device utilize the space-time energy pumped from the ether, which, according to the exposed theoretical background, is assumed to be the quantum-matter space-time. The energy absorption from an ether gravitational space takes place by means of vibrating electron-proton couples, the said energy being converted either into heat, or into mechanical or electrical work.

b. The state of the art

The state of the art relative to the present invention refers to the cold fusion technology. The comparative examination of the present invention with existing inventions takes place in chapter g

c. Theoretical background

The theoretical background of the present invention is the hypothesis of the quantum space-time (QST), which is based on the unification of the concepts being produced from the quantum mechanics (QM) and from the general relativity theory (GRT) as well. The QST hypothesis is cited on the following publications:

1. A. A. Nassikas, 1994. The Hypothesis of the Unified Field and the Principle of its Dual Interpretation. III International Conference: "Problems of Space, Time, Gravitation". Russian Academy of Sciences. St.Petersburg, Russia.
2. A. A. Nassikas, 1997. The Hypothesis and the Equations of the Unified Matter Field. Infinite Energy – Cold Fusion Technology, Inc. Vol. 3, No. 13 & No. 14. Also, 1996. International Conference "New Ideas in Natural Sciences". Russian Academy of Sciences. St. Petersburg, Russia.
3. A. A. Nassikas. The Hypothesis of the Quantum Space-Time-Aether. Accepted for publication in Galilean Electrodynamics. Special Issues 2000, No 2.

It is stressed that the possibility for the Cold Fusion effect explanation on the basis of the QST hypothesis and with reference to the star radiation (according to N.Kozyrev) has been firstly described by A. Frolov (The Source of Excess Energy. Infinite Energy, Vol.(4) Issue 20, 1998). In the present invention are described more accurate ways of explanation of the relevant phenomena as well as particular methods and embodiment devices of the invention objects.

According to the QST hypothesis the matter is the quantum space-time-ether. The mass constitutes a real gravitational space (g), while the electric charge constitutes an imaginary mass and electromagnetic (em) space, whose dimensions are imaginary numbers. The gravitational

space (g) can be converted into electromagnetic (em) space by means of photons and vice versa, while the energy conservation principle of a system refers to the total energy, i.e. to the gravitational energy E_g together with the electromagnetic energy E_{em} , which is considered to be imaginary. In a closed system the following relation applies:

5
$$\bar{E}_g + \bar{E}_{em-g} = \text{constant} \tag{1}$$

where the em-g index indicates a gravitational space energy equivalent to the electromagnetic space energy (E_{em}) and the dash (-) indicates the mean value. It is stressed that the energy of a system is a stochastic quantity, thus the mean value is meaningful . If we consider the Universe as a closed system, which has been derived from zero, then the following equation applies:

10
$$\bar{E}_g^U + \bar{E}_{em-g}^U = 0 \tag{2}$$

where the superscript ^U indicates Universe quantities. In a particle field, the following equation is valid according to the QST hypothesis:

$$\langle E \rangle \langle V \rangle = hc \tag{3}$$

i.e., the product of the energy expectation value of a particle field multiplied by the expectation value of the volume which contains that energy, is equal to hc. This means that $\langle E \rangle$ decreases as $\langle V \rangle$ increases and vice versa. In general, it can be proved that the volume \bar{V}_g increase of a closed system has as a result the energy \bar{E}_g decrease and vice versa. Thus, when \bar{E}_g^U is very high, the volume \bar{V}_g^U that contains \bar{E}_g^U will be very low. Big Bang means increase of \bar{V}_g^U and decrease of \bar{E}_g^U as well as increase of \bar{E}_{em-g}^U according to the equation (2). From the equation 20 (2) it is derived that for positive value of \bar{E}_g^U the \bar{E}_{em-g}^U value will be negative. Thus, the Universe evolution is a process reverse to that of the Universe creation, and during this evolution the quantity \bar{E}_g^U decreases tending to zero, while the quantity \bar{E}_{em-g}^U increases tending also to zero, given that the following equation is always valid:

$$|\bar{E}_g^U| = |\bar{E}_{em-g}^U| \tag{4}$$

25 We can assume that the charge energy \bar{E}_{em-g}^U is the charge energy sum of all the proton-electron couples. This means that the absolute value of the proton charge, assumed as negative energy, is greater than the electron charge -- assumed as positive energy -, so that the total \bar{E}_{em-g}^U will be negative. Actually, according to measurements referring to I.L. Gervolin's book "To Live Without Disasters, Higher Naval Engineering College. St. Petersburg 1991" the proton charge is 30 $4,803206815 \times 10^{-10}$ esu. According to the existing data the electron charge is $e = \sqrt{\alpha \hbar c} = 4,80319626 \cdot 10^{-10}$ esu. The charge difference between proton and electron, although its

accuracy is questionable because its magnitude class is 10^{-6} of the electron charge, it is much higher from the energy point of view, considering that from the energy point of view, the electron charge – considered to be a mass – is equivalent to $\alpha M_p = 7,299 \times 10^{16} m_{\text{neutron}}$, where α is the fine structure constant and M_p the Planck's mass. When there is a tendency for increase and nullification of \bar{E}_{em-g}^U , this means that there is an approach and coincidence tendency between the positive and negative charges of the proton-electron couples. The electron charge, if considered as an imaginary mass, is not constant but it varies with its velocity; thus, when electron approaches the proton, it will have a value able to neutralise it. Thus, the approach between electrons and protons has as a result the increase of \bar{E}_{em-g}^U and due to equation (2) the decrease of \bar{E}_g^U . Consequently we can assume that:

“During the approach between $e^- + P$, a gravitational space energy absorption takes place”.

However, it is brought up the question whether during the approach between $e^- + P$ the absorbed gravitational space originates from the system $e^- + P$ itself. Because of the quantum factor, the system $e^- + P$ does not collapse spontaneously but it is stable and requires external energy for the approach between $e^- + P$. This means that the absorbed gravitational space is external and does not originate from the system $e^- + P$ itself. Those things are clearer in the case where the electron is at the 1st fundamental state of the hydrogen atom, given that they are verified by the reaction:



which is endothermic as we can see. This reaction is mentioned by T. Mizuno and consideration of it will take place in chapter e. It must be stressed that after the 1st level there is no permitted situation other than the one corresponding to the elimination of the couple $e^- + P$ and to the neutron generation. It is noted that for the cold fusion technology as well as for the purposes of the present invention, the 1st level is the most interesting. However, relevant phenomena take place on other levels too. Indeed, according to N. Kozyrev's observations, the stars on which no nuclear reaction take place, are radiant and this radiation is proportional to the electrons density at the radiating area. This shows a relation between the radiation and the said electron-proton couples. However, because of the stability of the atoms structure there is no approach between electrons and protons. Thus, the star radiation phenomenon, according to all above mentioned, is interpreted as follows:

1. It takes place gravitational space energy absorption $\delta \bar{E}_g$ and its conversion to electromagnetic (em) space with energy equal to $\delta \bar{E}_{em-g}$ by photons. It is noted that the gravitational space energy absorption is compatible, as it has been mentioned, with the gravitational space energy reduction trend because of the Universe expansion.

2. Approach between protons and electrons due to the increase of \bar{E}_{em-g}

3. Reduction of \bar{E}_{em-g} to its initial value and distancing between protons and electrons with simultaneous emission of photons.

The increase and decrease of \bar{E}_{em-g} take place by means of unstable states that have a probability to exist, while the energy eigenvalue remains constant due to the structural stability of the atoms.

5 d. Space-Time Energy Pump

According to Classical Mechanics, in the hydrogen atom, the energy level of an electron in radius

$$r \text{ is: } E = -\frac{e^2}{2r} \quad (6)$$

The kinetic energy that the electron acquires during the free fall from radius $r = \infty$ to radius $r = r$ will be:

$$10 \quad E_{el} = \frac{e^2}{2r} \quad (7)$$

These equations are valid in Bohr's model.

According to the QST hypothesis, matter is the spacetime itself and the energy E_{el} is the energy-matter of the space within which this energy exists. The mean value of volume V_{el} that contains the energy E_{el} satisfies equation (3) i.e. it is valid that:

$$15 \quad V_{el}E_{el} = const. \quad (8)$$

According to Classical Mechanics, the transfer from one energy level E_{el} to a higher one takes place through action of the proton field on the electron.

According to the QST hypothesis, there is no action from a far distance and the energy increase is caused only by matter increase. Therefore, during the transfer from one level of energy E_{el1} to a higher level of energy E_{el2} which corresponds to a smaller radius r , we should have, according to the QST hypothesis, absorption of energy-matter by something that exists out of the space which encloses energy E_{el1} . Since the increase of E_{el} has as a consequence the decrease of the radius r , this means that the this increase corresponds to $e^- + P$ approach. According to what was mentioned above, the $e^- + P$ approach has as a consequence the absorption of gravitational space energy δE_g . The energy δE_g is the energy-matter which, according to the QST hypothesis, causes the increase of the level of energy E_{el} . However, according to the aforementioned, the transposition from E_{el1} to E_{el2} is equivalent to the transposition from the energy level $E_1 = -E_{el1}$ to the energy level $E_2 = -E_{el2}$.

If E_1 and E_2 correspond to fundamental energy levels of the electron in the hydrogen atom, then, as it is already known, photon emission will take place, according to the following equation:

$$30 \quad E_1 - E_2 = h\nu \quad (9)$$

Thus, during the transposition from energy E_{el1} to energy E_{el2} both gravitational space absorption and photon emission will take place. Applying the energy conservation principle, we result in the following equation:

$$E_{el1} + \delta E_g = E_{el2} + h\nu,$$

$$5 \quad \text{or} \quad \delta E_g = E_{el2} - E_{el1} + h\nu = (E_1 - E_2) + (E_1 - E_2) = 2(E_1 - E_2) = 2(E_{el2} - E_{el1}) \quad (10)$$

Thus, during the approach between $e^- + P$ which means transposition from energy E_{el1} to energy E_{el2} , a gravitational space energy absorption δE_g takes place that fulfills the following equation:

$$\delta E_g = 2(E_1 - E_2) = 2(E_{el2} - E_{el1}) = 2h\nu \quad (11)$$

When there is a transposition from the quantum level 1 to the quantum level 2, then δE_g is converted partly into photons ($h\nu = E_{el2} - E_{el1} = \delta E_g / 2$) and partly to energy increase in order to reach the energy E_{el2} ($E_{el2} = E_{el1} + \delta E_g / 2 = E_{el1} + E_{el2} - E_{el1}$). According to this analysis the energy E_{el} takes in addition into account the energy δE_g ; this is understood taking into consideration the relativistic changes of mass and load which is regarded as an imaginary mass.

It must be stressed that Bohr's model is empirically confirmed. Due to equation (9) the present analysis is not contradicted to Bohr's model but it takes in addition into consideration the relativistic changes of mass and load. However the question how the quantity e^2 is regarded as constant and the electron charge variable arises.

Equation (6) is based on the assumption that:

$$Q_{proton}(r) = -Q_{electron}(r) = e$$

20 This assumption, according to what was mentioned in chapter c, is not valid. Therefore, taking into account that Bohr's model is empirically confirmed and that e^2 is regarded as product of the proton charge by the electron charge, equation (6) could be written, in a more general form, as following:

$$E = \frac{Q_{proton}(r)Q_{electron}(r)}{2r} = -\frac{e^2}{2r}$$

25 Therefore we may assume that:

$$Q_{proton}(r)Q_{electron}(r) = -e^2$$

Taking into account the above mentioned we conclude that the electron when approaching the proton increases in charge until it is valid:

$$Q_{proton} = -Q_{electron} \quad \text{or} \quad Q_{proton} + Q_{electron} = 0$$

30 a fact that corresponds to charge disappearance and -according to eqn(5)- to neutron and neutrino production.

If we reach an energy level $E'_{el2} < E_{el2}$ corresponding to an unstable state, it will take place gravitational space energy absorption $\delta E'_g = 2(E'_{el2} - E_{el1})$ which under certain conditions may be rejected to the environment in the form of photons. Such a case is Kozyrev's star radiation case, as it has already been mentioned.

- 5 When reaching an unstable state E_2 lower than the fundamental E_1 in order that gravitational space absorption and photon emission are possible, the conditions of the equations (9,11) must be fulfilled. Consequently, it is valid: $E_1 - E_2 = h\nu$.

Let's assume that a negative potential is imposed on the hydrogen atom. Due to the negative potential no other permitted level interferes between the level $E_1 = -13,6 eV$ and the level

- 10 $E_\infty = 0$ and consequently the energy rejection must take place by photons of energy $-E_1$. Thus, it will be valid that:

$$E_1 - E_2 = -E_1 \text{ and } E_2 = 2E_1 \tag{12}$$

Equation (12) can be extended to energy levels in the form:

$$E_{k+1} = (k+1)E_1 \tag{13}$$

- 15 given that there is a difference $E_1 - E_{k+1} = -kE_1$, that is an integer multiple of $-E_1$ and consequently it can be rejected in the form of quanta with energy $-E_1$.

Reaching the state E_{k+1} a gravitational space absorption takes place according to eqn (11) so that we will have:

$$\delta E_{g\ k+1} = 2(E_1 - E_{k+1}) \tag{14}$$

- 20 From this amount of energy the part $E_1 - E_{k+1}$ is rejected in the form of photons as it has already been mentioned. The rest part $E_1 - E_{k+1}$, as it is not capable of getting incorporated into the unstable state E_{k+1} , is also rejected in the form of quanta of energy $-E_1$ given that the only stable state is E_1 . Because of the equations (13,14) it is valid:

$$\delta E_{g\ k+1} = k \times 27,2 eV \tag{15}$$

- 25 It is noted that eqn (15) has been derived from eqn (11) as if the states E_{k+1} were stable; it is also noted that we cannot exclude graviton emission when electron moves from E_{k+1} to E_1 . Thus, we could regard this phenomenon as stochastic; the possibility for photon emission is reinforced by the Kozyrev star radiation which takes place under constant matter structure (without nuclear reactions).

- 30 The equation (15) is similar to Mills' equation for the rejected energy during the conversion of Hydrogen's atom to a Hydrino. Nevertheless, the levels E_{k+1} are unstable and different from those

given by Mills. Also, the radius r_{k+1} corresponding to the level E_{k+1} will be such, due to the equations (7,8), that:

$$E_{k+1} \cdot r_{k+1} = E_1 \cdot r_1 \quad (16)$$

and consequently it will be $r_{k+1} = r_1 / (k + 1)$. Thus, compared with the model proposed by Mills, the rejected energy $\delta E_{g_{k+1}}$ is the same for the same radii r_{k+1} , but the energy levels E_{k+1} are different. It is noted that the equation (16) is a relation which, as already mentioned, satisfies all levels of Bohr's model and consequently does not lead to any attitude's change of whatever happens lower than the 1st level.

On the basis of the aforementioned analysis of chapter c, we can compose a space-time energy pump which can convert the ether's space-time energy to thermal energy or to mechanical or electrical work, by means of a system that displaces the electron of the E_1 fundamental level of the hydrogen atom to an unstable energy level E_{k+1} and returns it to the state E_1 . In such a system the aforementioned will take place, i.e. gravitational space energy absorption $\delta E_{g_{k+1}}$ and its conversion into photons with simultaneous return of the electron to the stable situation E_1 under the condition that the aforementioned system imposes the energy level E_1 as the unique stable situation permitted. Due to the conversion of the energy $\delta E_{g_{k+1}}$ into photons, there will arise:

1. Probability of photon emission.
2. Probability of photons conversion into mass (gravitons) which rearranges the mass distribution of a material space-time field by movement of the body which moves due to the said photons conversion. This case will be examined in detail at the preferred embodiments of the invention.
3. Probability of photons conversion into mass within the proton mass area. This mass has a probability to have high energy due to the fact that the phenomenon is stochastic.
4. Probability of photons to be reconverted into a gravitational space energy of the surroundings.

e. Interpretation of the cold fusion phenomena.

During the heavy water electrolysis, heavy hydrogen is formed on the cathode and oxygen on the anode. When palladium is used as a cathode, the heavy hydrogen is absorbed inside the palladium. Because of the negative cathode potential, the heavy hydrogen electron is on the 1st level and a force is exerted on it, pushing it towards the nucleus. Thus, it will take place an approach between $e^- + P$ by means of unstable states, in the same way as it has already been mentioned in the chapters d and c for the radiation of Kozyrev's stars. These unstable levels are probable to exist while the energy eigenvalue will remain at the permitted energy level E_1 . In this way, a space-time energy pump will be formed, having as a result the gravitational space energy pumping and the production of photons that heat the whole electrolytic system.

The above mentioned are also effective in the case of light water electrolysis given that exactly the same mechanisms are being activated in the cases of both the heavy and the normal hydrogen. Thus, Mills' patent WO92/10838 can be explained on the basis of the space-time energy pump; more details are given in chapter g.

5 The aforementioned concern an excess heat generated without any reaction. However, during the cold fusion phenomena there is detection of nuclear reaction products. The explanation given by Conte according to Mizuno (detailed reference is made in T. Mizuno's book "Nuclear Transmutation, Infinite Energy Press 1998") covers the whole range of nuclear reactions which take place during the cold fusion, i.e. neutron, helium and tritium generation reactions,
 10 transmutation phenomena, etc, but without explaining the discrepancy among the nuclear reactions, the produced heat and the products of the nuclear reactions. This discrepancy is due to heat generation by conversion of gravitational space to heat as described above, without the existence of nuclear reactions. We can notice that the explanation of Conte-Mizuno is facilitated as well on the basis of the space-time energy pump mechanism and especially by finding out that
 15 "during the approach between $e^- + P$, a gravitational space energy absorption takes place". Indeed, according to Conte-Mizuno explanation, the following reaction takes place during the approach between electrons and protons:



20 The energy of 0,783 MeV according to Conte-Mizuno explanation, is covered by the electron capability to have – according to quantum mechanics – a presence probability under high energy as well as by the developing of an excess potential in very small distances between electron and proton. However, the energy of 783000 ev is difficult to be handled by means of low voltages. Thus, it is expected that the reactions (17,18) are significantly facilitated by the gravitational
 25 space energy absorption during the approach between $e^- + P$, which is not rejected but it is used for the creation of the next stable state ($n + \text{neutrino}$). Furthermore, there is the probability of hydrogen isotope direct fusion, by means of the space-time energy pump mechanism. As it has already been mentioned in chapter d.3, a possible consequence of the ether gravitational space absorption is the creation of high energy mass presence probability in the proton or deuteron
 30 nucleus. Thus, it is probable that two adjacent deuteron nuclei -facilitated by the palladium or other metal grid in which they lie – will acquire a high mass that will develop an attraction which will overcome the Coulomb barrier. This case is being mentioned because it has already been used without the interference of the absorbed gravitational space as a possible explanation. Because of the existence of an external factor, such as the gravitational space energy absorption,
 35 this explanation gets greater possibility to be considered as reasonable.

f. Preferred embodiments

The description of the present invention will be done with indicative devices showing its capabilities without restricting its scope.

According to a first preferred description, the present invention is embodied as follows:

- 5 We create two metallic zones. Zone 1 consists of a metal with a very small hydrogen solubility. According to a preferred embodiment, this zone is made of copper with a width of 6mm. Zone 2 is made of a metal layer in the lower part of zone 1. This metal has a large hydrogen solubility. According to a preferred embodiment, this metal is nickel plating on the lower part of zone 2 and its width is 1,5mm.
- 10 The metal zone 2 is hydrogenated, according to the known state of the art, by means of electrolysis or by placing the whole system (zones 1,2) in atomic hydrogen atmosphere. The plate 1 is connected by means of the insulating material 8 to the metal carrier 3, forming thus the cooling channels 4. The cooling fluid won't be conductive. According to a preferred embodiment, the cooling fluid is the air. According to another preferred embodiment the cooling fluid is oil.
- 15 The plate 1 is connected through the cable 7 with the device 5, which comprises power supply and circuits for the generation of negative electric pulses and the adjustment of their characteristics. The rejected heat $\delta E_{g\ k+1} = k \times 27,2\ eV$ is achieved due to the development of unstable energy states $E_{k+1} = -(k+1) \times 13,6\ eV$ by adjusting the negative pulse voltages in the system 5. According to a preferred embodiment, the generated electric pulse is the one depicted in figure 2, the voltage
- 20 V_A is determined by adjustment in the range from 0 to $-500\ V$ in order to exist energy states $E_{k+1} = -(k+1) \times 13,6\ eV$ the pulse frequency is 1000 Hz and the difference $V_A - V_B$ is determined by adjustment in the range from 0 to $-120V$. According to another preferred embodiment the electric pulse becomes a constant voltage with $V_B = V_A$ which aims to produce energy levels $E_{k+1} = -(k+1) \times 13,6\ eV$. During the negative voltage application, in the hydrogenated area 2 will
- 25 appear hydrogen atoms with electrons located on the 1st fundamental level. Due to the negative voltage, all the phenomena mentioned in chapters d,e and f. will take place i.e. an electron oscillation due to unstable states under the 1st fundamental level as well as gravitational space (g) absorption. More specifically, because of the negative voltages we have electron of 1st fundamental state moving from energy state E_1 to energy state E_{k+1} by means of the electrical
- 30 field which offers to the electron an energy equal to $E_1 - E_{k+1}$.
- According to equations (11,14) we will have, during this electron transposition, a gravitational space absorption with energy equal to $\delta E_{g\ k+1} = 2(E_1 - E_{k+1})$
- During the electron return from energy state E_{k+1} to energy state E_1 the electron overcomes the field through one part of energy $\delta E_{g\ k+1}$ which has been absorbed, as it was mentioned, by the

gravitational space i.e. through energy equal to $E_1 - E_{k+1}$. Thus, we have another part of energy $\delta E_{g_{k+1}}$ which equals to $E_1 - E_{k+1}$ which has a probability to be converted into photons or into gravitons as it has been mentioned in section d. It is noted that, as it was mentioned in chapter d, the phenomenon described is stochastic; i.e. the whole process has a probability to occur. The pulses mentioned are used in order to destabilize the voltage gradient created in the 1st fundamental level electron area of the hydrogen atom.

According to the aforementioned facts in the chapters d, e and f, the absorbed gravitational space energy is converted into photons which heat the plate 1, which in turn maintains its temperature due to the cooling system with channels 4. The temperature regulation in a desirable level can be achieved by means of the cooling fluid in channel 4 according to the existing level of art.

According to the QST hypothesis, a body is attracted in a gravitational space because the space-ether under the body has a higher matter presence probability than the space over the body.

During the pulse initiation of figure 2, due to gravitational space absorption by the area 2, there will be a reduction of the matter presence probability on the lower side of the body in figure 1 and consequently a creation of a force F opposite to the gravity's one. The absorbed gravitational space-time-ether has the capability to reach the hydrogenated area 2 through the material system that surrounds the area 2. However, the ether is material and it is attracted by the heavier bodies more than by the lighter ones. Thus, the ether finally enters the area 2 following the shortest and the least attracting path, i.e through the passages 6 of figure 1. When the body of figures 3,4 has a vertical position, then it wil start moving under the action of the force F, due to the ether density difference as it has already been mentioned. According to the 1st reference of chapter c, the force exerting upon an element defined by the elementary surface dydx and by the values z_1, z_2 , in the reference space-time of a matter system having a matter presence probability equal to $P(r,t)$, will be:

$$dF_z = \langle E \rangle dx dy [(P(r,t)_{z_2} - P(r,t)_{z_1})] \tag{19}$$

where $\langle E \rangle$ is the energy expectation value of the whole material system. When $P(r,t)$ is considered to be constant on the extent of a surface f of the reference space-time for constant z, then the equation (19) can be written as follows:

$$F_z = \langle E \rangle f [(P(r,t)_{z_2} - P(r,t)_{z_1})] \tag{20}$$

If $P(r,t)$ is constant in z_1 and varies only in z_2 , then the developing force difference can be expressed as follows:

$$\delta F_z = \langle E \rangle f \delta P(r,t)_{z_2} \tag{21}$$

We notice that the developing force difference is caused by the difference $\delta P(r,t)_{z_2}$.

The development of the force δF_z has as a result the movement of the body on which it is exerted and the rearrangement of the matter presence probability of the whole system. This rearrangement takes place at the expense of the absorbed gravitational space energy in the area 2 which has as result a graviton emission which supplies the necessary mass according to the relativity theory for the body motion. During the operation of the whole system, there is an input power N_{input} required for the pulse generation as well as an absorbed gravitational space power \dot{E} being equal to the system's excess power, i.e. $\dot{E} = (cop - 1) \cdot N_{input}$. When the produced mechanical power is less than the power \dot{E} , then there will be simultaneous heat rejection –through the channel 4- so that the energy conservation principle will be applied. When the produced mechanical power is equal to \dot{E} then it will take place heat rejection that will be equal to N_{input} .

According to a second preferred description the device of figure 1 is put on the shaft 9 which is seated on the bearing 13 and is supplied with electric pulses through the electric contact element 10 the cable 7 and the system 5. The element 10 is manufactured on the basis of the electric machine technology data. According to a preferred embodiment, the element 10 consists of carbon rings pressed by springs. The shaft 9 has a coupling 11 consisting of insulating material so that the electric pulses will not be diffused. The force F is exerted in a way similar to that of figure 1 and as depicted in figure 4. Due to the created moment, a rotary motion is created, producing electric power 12 by means of the generator 14. According to a preferred embodiment the produced mechanical power is equal to the power produced by the gravitational space absorption. In this case the heat rejection that is equal to N_{input} takes place through the ambient air.

According to a preferred embodiment the vanes of the mechanism of figure 4 are more than two. According to a third preferred description the plate system (1,2) is connected to the plate 15 and they are both fixed on the support 19 by means of the insulating material 18. According to a preferred embodiment the width of plates 1,2 and 15 is 2mm, 1mm and 2mm respectively. Due to the symmetry of the plates 1, 15 there is no preferential absorption of gravitational space from the one and consequently there is no force development. Through the metal sheets 20 there are created conduits through which flows the cooling fluid of the plates 1,15. The cooling fluid enters through the inlets 16 and leaves through the outlets 17. The hydrogenated area 2 is subjected to electric pulses by means of the cable 7 and the system 5, as it has already been mentioned in the former descriptions. Due to the fact that the system is stationary, it takes place a conversion of the gravitational space absorbed by the area 2 into heat and an operation of the system as a heater. According to a preferred embodiment the cooling fluid is air. According to another preferred embodiment the cooling fluid is oil.

g. Comparison with former inventions

From the existing state of the art arise the following:

1. The invention of F. Pianteli, 1995, WO95/20816 constitutes a solid structure mechanism with metal which is hydrogenated from the beginning. The differences with the present disclosure
5 consist in the following:

1.1 The fact of the different principle of operation. According to the invention WO95/20816, a high energy shock is created which leads to hydrogen isotopes fusion. On the contrary the present invention is based on the ether gravitational space absorption having as a result the heat emission without nuclear reaction.

10 1.2 In the present disclosure there is a no symmetrical loading with hydrogen (loading from one side only). Due to the ether absorption, there is a matter presence probability reduction at the hydrogenated side and a creation of a force directing to the increased presence probability side. By this force we have the capability of direct conversion of the space-time energy into mechanical or electrical work. In the invention WO95/20816 there is not such a capability.

15 2. The invention of R. Mills WO92/10838 constitutes a method and device for energy production by means of light water electrolysis , using electric pulses.

The difference with the present invention consists in the following:

2.1 According to the invention WO92/10838, the energy production results from the formation of shrunk hydrogen atoms (Hydrinos) which have fractional electron energy level
20 number. This process has as a result the continuous feeding with atomic hydrogen for the replacement of Hydrinos. In contrast with the present invention where the energy is produced by conversion of gravitational space into mechanical work or heat by means of a stable carrier, i.e. by means of the hydrogenated part 2 of the plate 1. Any hydrogen loss in the present disclosure is not caused by operational reasons but by possible loss due to molecular
25 diffusion.

2.2 For the embodiment of the invention WO92/10838, it is required the use of energy holes which receive the energy generated when a hydrogen atom is converted into a Hydrino. According to the present invention there are no stable states lower than the fundamental level. The existing states are unstable and have as a result the gravitational space energy
30 absorption, rejecting it to the environment when they return at the fundamental level. The gravitational space absorption condition ($\delta E_{g_{k+1}} = kx27.2 eV$) is achieved by means of unstable energy states $E_{k+1} = -(k+1)x13.6 eV$, which are achieved by regulating the negative voltages in the negative pulse generation and control system 5.

2.3 In the present disclosure there is no symmetrical loading with hydrogen (loading from one
35 side only). The ether gravitational space absorption results in matter presence probability

reduction at the hydrogenated side and in the creation of force directed to the increased presence probability side. By means of this force there is the capability for direct conversion of the space-time energy into mechanical or electrical work. In the invention WO92/10838 such a capability does not exist.

5

Notice:

1. The materials which have been mentioned are not exclusively used for the purposes of this patent; instead of them we can use materials with properties similar to those which are required for these purposes.
- 10 2. The following improvements are possible:
 - a. Improvement of the system so as to function under high temperatures which means protecting the lower part of zone 2 against hydrogen leak. This improvement is possible by means of SiO_2 layer through laser technique.
 - b. Zone 1 can be made in such a way that it will include within it channel 4. Thus, SiO_2 protection of improvement 2.a. is applied in the whole extent of the external surfaces of
15 zones 1 and 2.
 - c. Improvement 2.b. can be applied to the 2nd preferred description (fig. 3,4). In this way we can have cooled wings. The cooling medium can flow in the wings through holes and passages in axis 9 while the inlet and outlet in this axis can be made through collectors
20 which are connected to axis 9 through sealing arrangements.
 - d. In the case of the 3rd description, it is possible that zone 1 will be a copper pipe and channel 4 will be the inner part of this pipe, while carrier 2 will be nickel plating on the outer part of the pipe mentioned. In this case, zones 1 and 2 will have to receive current
25 only through cable 7 and to be electrically insulated against the rest external environment.

30

35

CLAIMS

1. Method for the conversion of space-time energy into mechanical work by absorbing space-
5 time-ether energy by approaching-distancing between proton-electron through unstable
electron energy states under the 1st fundamental state in the hydrogen atom, by means of:
- Ether energy absorption by hydrogenated metallic carrier and conversion of this energy
into photons which are emitted to the surroundings or are converted into gravitational
space which changes the ether-matter presence probability.
 - 10 - A metallic zone with very small solubility of Hydrogen in this zone.
 - A metallic hydrogenated carrier with high solubility of Hydrogen in this zone.
 - Electrical oscillations of negative potential and regulated characteristics applied on the
said hydrogenated carrier in such a way that the conditions of ether energy absorption and
energy emission are satisfied.
 - 15 - Placement of the hydrogenated carrier on the one side of the movable body.
 - Force exertion on the body due to creation of ether-matter presence probability density
difference at the ends of the movable body and especially due to the reduction of the
matter presence probability density at the side where the hydrogenated carrier is placed.
 - Means for the rejection of the developed heat.
- 20
2. Mechanism for the conversion of the space-time energy into mechanical work by means of a
material system that embodies the purposes of claim 1, where:
- The metallic zone 1 is copper.
 - The metallic hydrogenated carrier 2 is a nickel plating on the zone 1.
 - 25 - The electric oscillations of negative potential are imposed on the nickel plating 2 and the
metallic zone 1 by means of an electric oscillations supply and characteristics regulation
system, where metallic zones 1 and 2 are electrically isolated from the rest of the system
by means of insulating material 8 and insulation cooling means which flows in the
channel 4.
 - 30 - The force is exerted along the direction from zone 2 towards plate 3 of the material
system's other side by creating a probability density difference between the ether
underneath the plating 2 and the ether above the side 3.
 - The heat rejection is achieved through insulation cooling fluid passing through the
channel 4.

35

3. Mechanism for the conversion of space-time energy into both rotary motion and electric work, comprising a shaft 9 having plate-like mechanisms similar to that of claim 2 fixed on it, the said force exertion creating a torsion that rotates the shaft 9 and results in the creation of electric work by the interference of the generator 14.

5

4. Heat generation mechanism like the mechanism of claim 2, having the produced mechanical work being equal to zero and using only the cooling channels for the heat transfer by the cooling fluid, the elimination of the mechanical work being achieved by means of the copper plate 15 which abolishes the preferential inlet of the ether from a certain side, and the cooling conduits being formed between the plates 1, 15 and the metal sheets 20.

10

5. Heater as the one of claim 4 where zone 1 is a copper pipe and channel 4 is the inner part of the pipe while the carrier 2 is nickel plating on the external surface of the mentioned pipe.

1/3

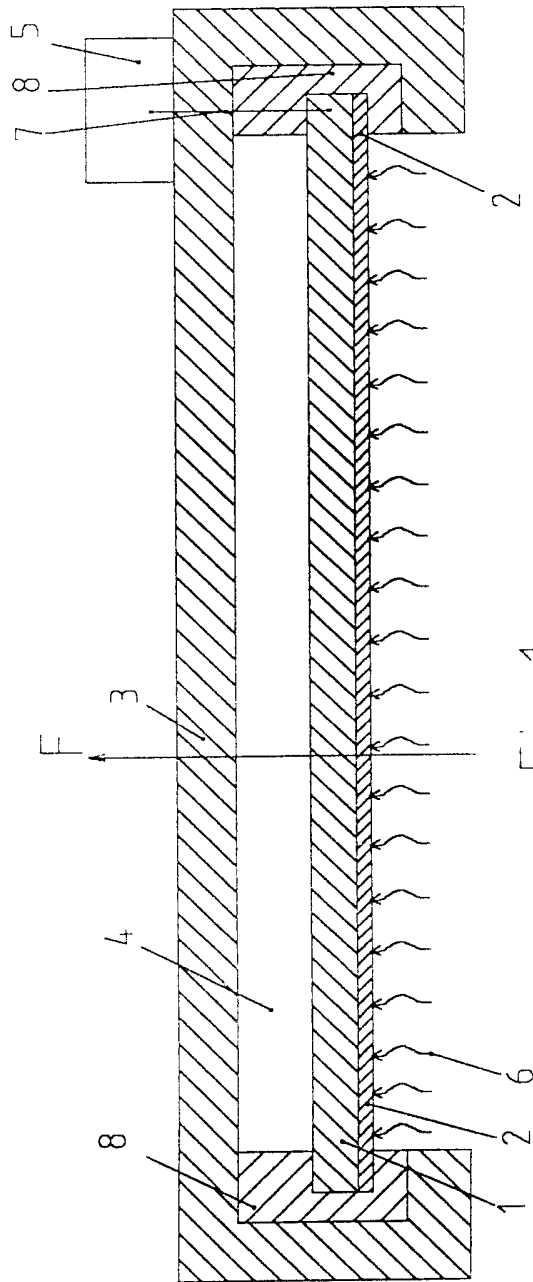

Fig 1

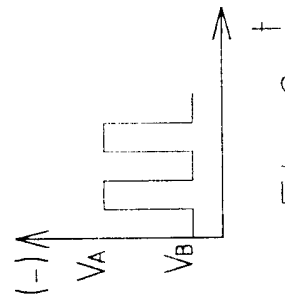

Fig 2

2/3

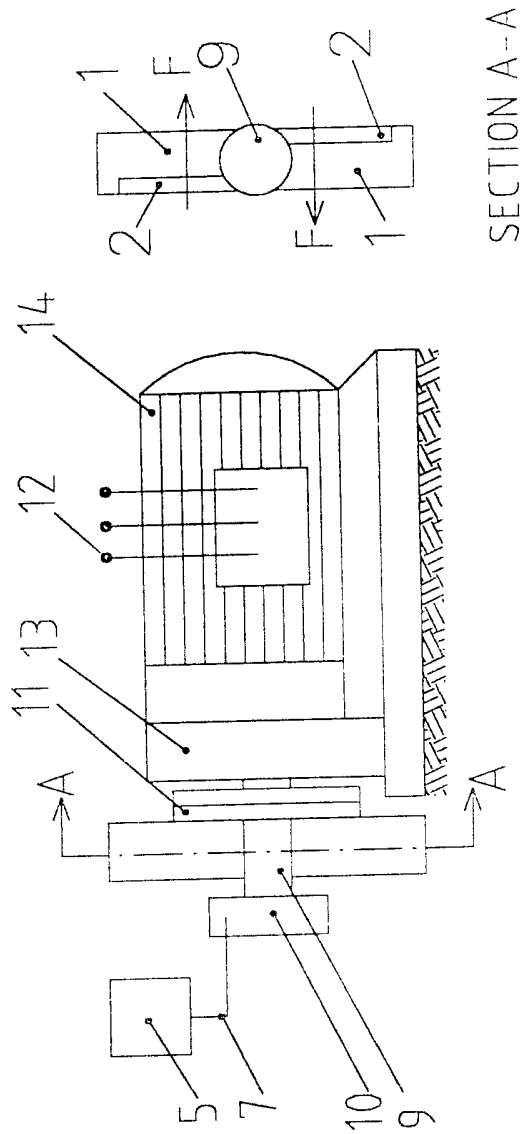
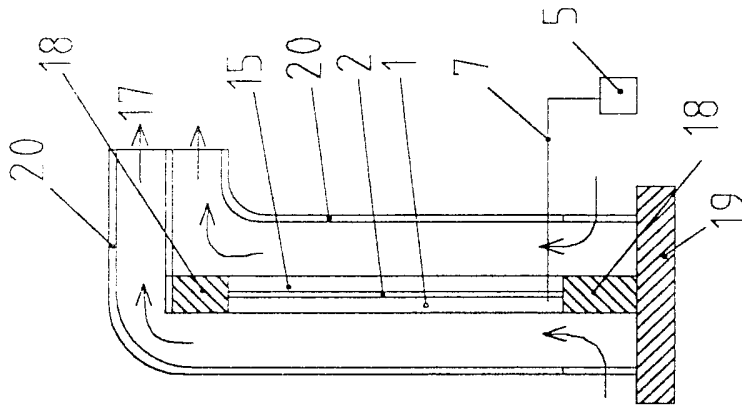

Fig 4

Fig 3

3 / 3



SECTION B-B

Fig 6

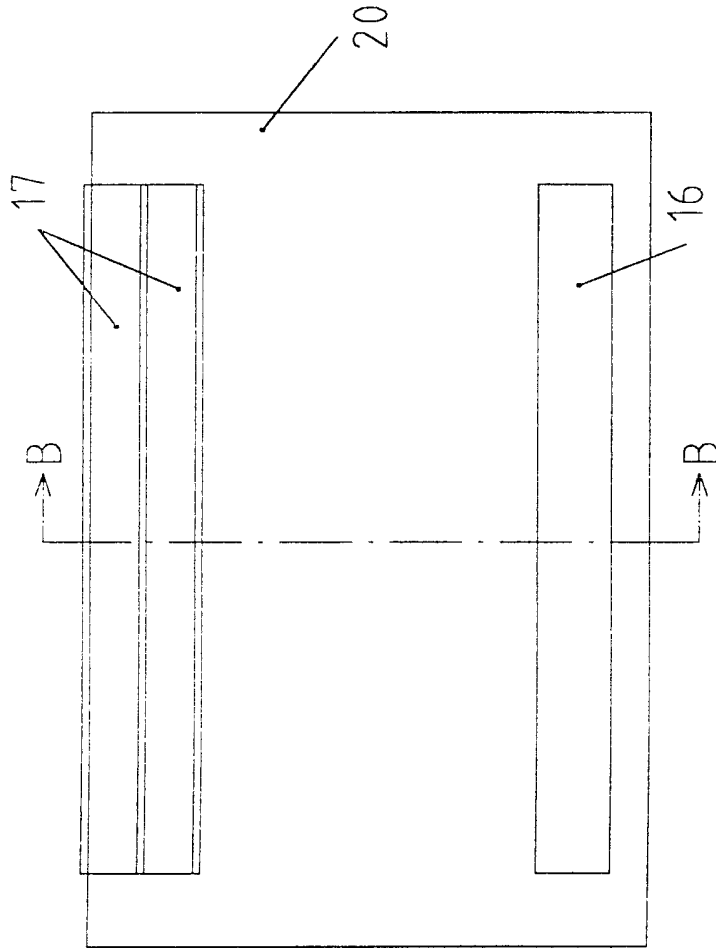

Fig 5

INTERNATIONAL SEARCH REPORT

Int. Patent Application No

PCT/GR 00/00041

A. CLASSIFICATION OF SUBJECT MATTER
IPC 7 G21B1/00

According to International Patent Classification (IPC) or to both national classification and IPC

B. FIELDS SEARCHED

Minimum documentation searched (classification system followed by classification symbols)
IPC 7 G21B

Documentation searched other than minimum documentation to the extent that such documents are included in the fields searched

Electronic data base consulted during the international search (name of data base and, where practical, search terms used)

WPI Data, PAJ, INSPEC, EPO-Internal

C. DOCUMENTS CONSIDERED TO BE RELEVANT

Category	Citation of document, with indication, where appropriate, of the relevant passages	Relevant to claim No.
A	DE 41 23 995 A (HORA HEINRICH) 21 January 1993 (1993-01-21) the whole document ---	1,2
A	DE 40 27 784 A (HORA HEINRICH) 30 April 1992 (1992-04-30) the whole document ---	1,2
A	WO 95 20816 A (FOCARDI SERGIO ;HABEL ROBERTO (IT); PIANTELLI FRANCESCO (IT)) 3 August 1995 (1995-08-03) cited in the application page 4, line 30 -page 6, line 3 ---	1,5
A	EP 0 393 465 A (SEMICONDUCTOR ENERGY LAB) 24 October 1990 (1990-10-24) claims 4,6,8 --- -/--	1

Further documents are listed in the continuation of box C.

Patent family members are listed in annex.

Special categories of cited documents :

- *A* document defining the general state of the art which is not considered to be of particular relevance
- *E* earlier document but published on or after the international filing date
- *L* document which may throw doubts on priority claim(s) or which is cited to establish the publication date of another citation or other special reason (as specified)
- *O* document referring to an oral disclosure, use, exhibition or other means
- *P* document published prior to the international filing date but later than the priority date claimed

- *T* later document published after the international filing date or priority date and not in conflict with the application but cited to understand the principle or theory underlying the invention
- *X* document of particular relevance: the claimed invention cannot be considered novel or cannot be considered to involve an inventive step when the document is taken alone
- *Y* document of particular relevance: the claimed invention cannot be considered to involve an inventive step when the document is combined with one or more other such documents, such combination being obvious to a person skilled in the art.
- *Z* document member of the same patent family

Date of the actual completion of the international search

4 April 2001

Date of mailing of the international search report

10/04/2001

Name and mailing address of the ISA

European Patent Office, P.B. 5818 Patentlaan 2
NL - 2280 HV Rijswijk
Tel. (+31-70) 340-2040, Tx. 31 651 epo nl.
Fax: (+31-70) 340-3016

Authorized officer

Capostagno, E

INTERNATIONAL SEARCH REPORT

Int. Application No PCT/GR 00/00041
--

C.(Continuation) DOCUMENTS CONSIDERED TO BE RELEVANT		
Category °	Citation of document, with indication, where appropriate, of the relevant passages	Relevant to claim No.
A	WO 98 07898 A (MILEY GEORGE H) 26 February 1998 (1998-02-26) page 4, line 12 - line 18 ----	1,2
A	WO 92 08232 A (HEREDY LASZLO A) 14 May 1992 (1992-05-14) page 13, line 20 -page 14, line 19 ----	1,2
A	WO 90 13126 A (MILLS RANDELL L) 1 November 1990 (1990-11-01) -----	

INTERNATIONAL SEARCH REPORT

Information on patent family members

International Application No

PCT/GR 00/00041

Patent document cited in search report		Publication date	Patent family member(s)	Publication date
DE 4123995	A	21-01-1993	DE 4009604 A DE 4027784 A	20-02-1992 30-04-1992
DE 4027784	A	30-04-1992	DE 4009604 A DE 4123995 A	20-02-1992 21-01-1993
WO 9520816	A	03-08-1995	IT SI940001 A AT 180918 T AU 691242 B AU 1589095 A BG 100797 A BR 9506650 A CA 2182102 A CN 1139990 A CZ 9602226 A DE 69510056 D DE 69510056 T EP 0767962 A ES 2133732 T FI 963010 A HU 76408 A JP 9508212 T NO 963149 A NZ 279311 A PL 315654 A SK 97896 A	27-07-1995 15-06-1999 14-05-1998 15-08-1995 30-09-1997 02-09-1997 03-08-1995 08-01-1997 16-07-1997 08-07-1999 03-02-2000 16-04-1997 16-09-1999 29-07-1996 28-08-1997 19-08-1997 26-09-1996 25-03-1998 25-11-1996 09-07-1997
EP 0393465	A	24-10-1990	JP 2280092 A JP 3041391 A	16-11-1990 21-02-1991
WO 9807898	A	26-02-1998	AU 4075497 A EP 0944748 A	06-03-1998 29-09-1999
WO 9208232	A	14-05-1992	NONE	
WO 9013126	A	01-11-1990	AU 5642990 A BR 9007303 A CA 2054697 A EP 0469073 A JP 4504906 T	16-11-1990 24-03-1992 22-10-1990 05-02-1992 27-08-1992